

PLATOS DE DUCHA
SHOWER TRAYS | RECEVEUR DE DOUCHE | PIATTI DOCCIA

BASIC

GELCOAT





Texturas disponibles | Available textures | Textures disponibles | Texture disponibili



SLATE

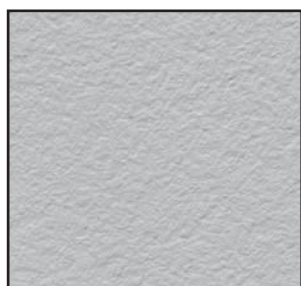

GRANITO



LISO

Colores disponibles | Available colors | Couleurs disponibles | Colori disponibili



BLANCO

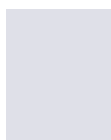

POLAR

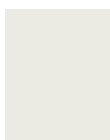

MARFIL

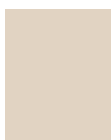

PERLA



ARENA



ALBERO



HUMO



CONCRET



TUNDRA



ANTRACITA



NEGRO

COLORES RAL / NCS DISPONIBLES BAJO PEDIDO | RAL/NCS COLORS AVAILABLE ON REQUEST | COULEURS RAL/NCS DISPONIBLES SUR DEMANDE | COLORI RAL/NCS DISPONIBILI SU RICHIESTA

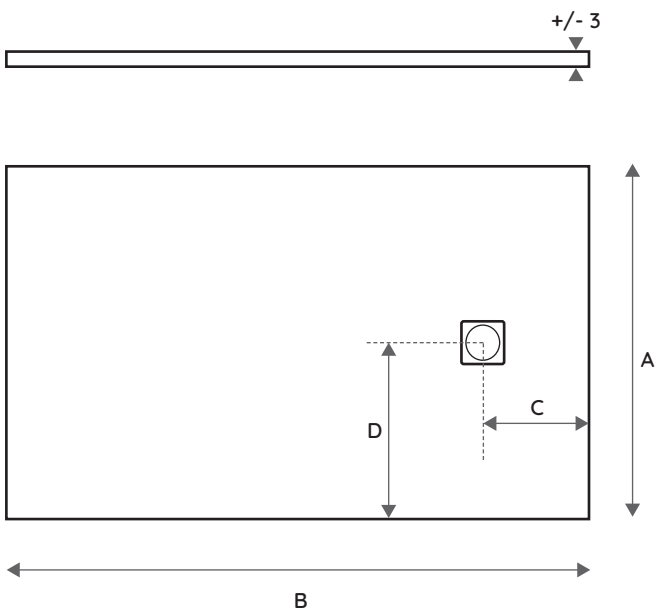
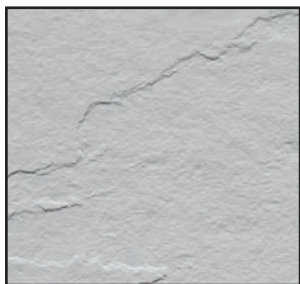

A	B	C	D	REF.
70	100	40	35	255
	110	40		280
	120	40		256
	130	40		281
	140	40		257
	150	40		282
	160	40		258
	170	60		283
	180	60		259
	200	60		254
75	90	40	37,5	420
	100	40		422
	120	40		424
	130	40		425
	140	40		426
	150	40		427
	160	40		428
	170	60		429
	180	60		430
	190	60		431
200	60	432		
80	80	40	40	253
	90	40		292
	100	40		260
	110	40		284
	120	40		261
	130	40		285
	140	40		262
	150	40		286
	160	60		263
	170	60		287
	180	60		264
	190	60		288
200	60	265		
90	90	40	45	290
	100	40		289
	120	45		266
	140	45		267
	160	50		268
	180	60		269
	200	60		270
100	100	50	50	271
	120	45		293
	140	45		272
	160	60		294
	180	60		273
	200	60		274
215	60	295		
110	200	60	55	275

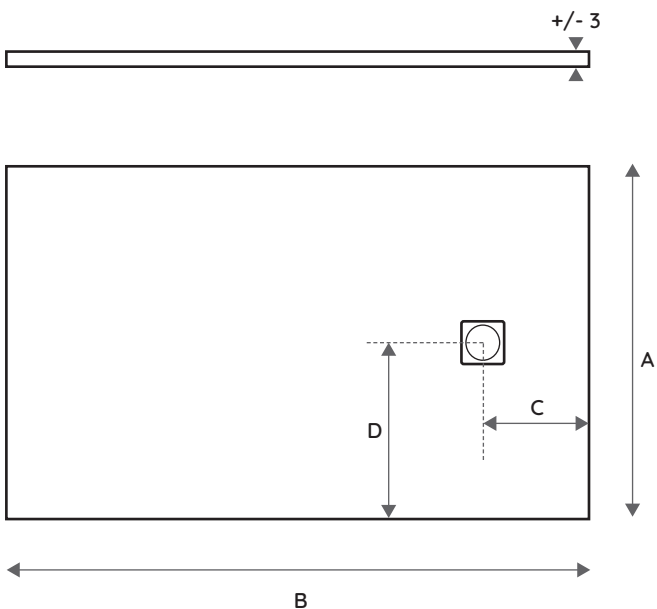

A	B	C	D	REF.
70	90	40	35	449
	100	40		450
	110	40		451
	120	40		452
	130	50		453
	140	50		454
	150	45		455
	160	45		456
	170	60		457
	180	60		458
200	60	459		
80	90	40	40	492
	100	40		461
	110	40		462
	120	40		463
	130	50		464
	140	50		465
	150	45		466
	160	45		467
	170	60		468
	180	60		469
190	60	470		
200	60	471		
90	90	40	45	490
	100	40		472
	120	40		474
	140	50		476
	160	45		478
	180	60		480
100	100	40	50	483
	140	50		485
120	140	50	60	491

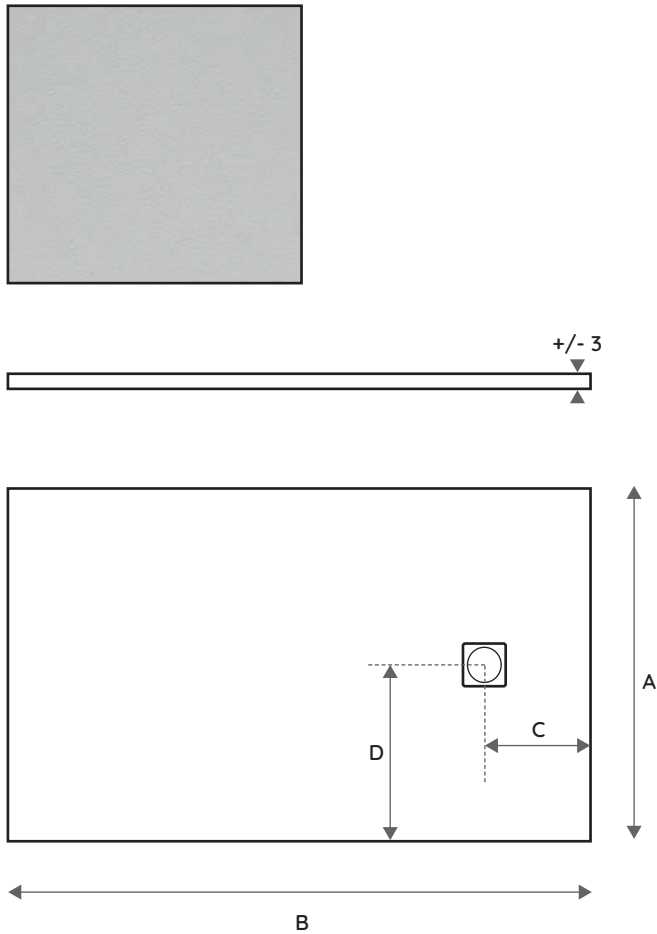

A	B	C	D	REF.
70	100	40		
	110	40		
	120	40		
	130	50		
	140	50	35	-
	150	45		
	160	45		
	170	60		
	180	60		
	200	60		
80	100	40		
	110	40		
	120	40		
	130	50		
	140	50		
	150	45	40	-
	160	45		
	170	60		
	180	60		
	190	60		
90	90	40		
	100	40		
	120	40		
	140	50	45	-
	160	45		
	180	60		
100	100	40	50	-
	140	50		
120	140	50	60	-

Válvulas | Valve | Valve | Valvola

Tempoplex 90 H

0,55 L/seg.

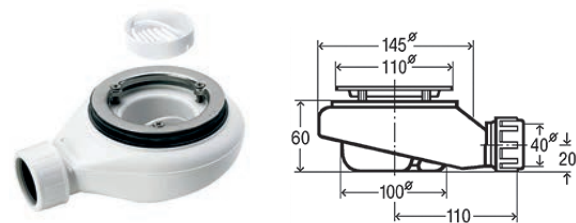

Rejillas | Grid | Grille | Griglia

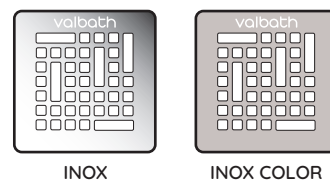

KIT REPARACIÓN

PARA PEQUEÑAS REPARACIONES. INCLUYE PINTURA, CATALIZADOR, HERRAMIENTA, GUANTES E INSTRUCCIONES | FOR SMALL REPAIRS. INCLUDES PAINT, CATALYST, TOOL, GLOVES AND INSTRUCTIONS | POUR LES PETITES RÉPARATIONS. COMPREND LA PEINTURE, LE CATALYSEUR, L'OUTIL, LES GANTS ET LES INSTRUCTIONS | PER PICCOLE RIPARAZIONI. INCLUDE VERNICE, CATALIZZATORE, STRUMENTO, GUANTI E ISTRUZIONI.

KIT REPINTADO

PARA GRANDES REPARACIONES. INCLUYE PINTURA, CATALIZADOR, HERRAMIENTA, GUANTES E INSTRUCCIONES | FOR BIG REPAIRS. INCLUDES PAINT, CATALYST, TOOL, GLOVES AND INSTRUCTIONS | POUR LES GROSSES RÉPARATIONS. COMPREND LA PEINTURE, LE CATALYSEUR, L'OUTIL, LES GANTS ET LES INSTRUCTIONS | PER GRANDI RIPARAZIONI. INCLUDE VERNICE, CATALIZZATORE, STRUMENTO, GUANTI E ISTRUZIONI.

GEL COAT

Compacto fabricado a base de resinas, cargas minerales formuladas y acabado superficial con nuestro Gel-Coat especial de altas prestaciones (isoftálico sanitario, sin poro, tratamiento U.V., antibacterias, alta resistencia) utilizado en la industria naval y aeronáutica.

Con este último acabado, evitamos problemas de hidrólisis a medio y largo plazo superando a la vez todas las exigencias de la norma UNE-EN 14527 y obteniendo de esta forma el marcado CE para nuestros platos de ducha.

Compact manufactured from resins, formulated mineral fillers and surface finish with our special high performance Gel-Coat (sanitary isophthalic, non-porous, U.V. treatment, antibacterial, high resistance) used in the naval and aeronautical industry.

With this last finish, we avoid hydrolysis problems in the medium and long term, overcoming at the same time all the requirements of the UNE-EN 14527 standard and obtaining in this way the CE marking for our shower trays.

Compact fabriqué à partir de résines, de charges minérales formulées et finition superficielle avec notre Gel-Coat spécial de haute performance (isophtalique sanitaire, non poreux, traitement U.V., anti-bactérien, haute résistance) utilisé dans l'industrie navale et aéronautique. Grâce à cette dernière finition, nous évitons les problèmes d'hydrolyse à moyen et long terme, tout en dépassant toutes les exigences de la norme UNE-EN 14527 et en obtenant ainsi le marquage CE pour nos receveurs de douche.

Compattato prodotto con resine, cariche minerali formulate e finitura superficiale con il nostro speciale Gel-Coat ad alte prestazioni (isofthalico sanitario, non poroso, trattamento U.V., antibatterico, ad alta resistenza) utilizzato nell'industria navale e aeronautica.

Con quest'ultima finitura, evitiamo i problemi di idrolisi a medio e lungo termine, superando tutti i requisiti della norma UNE-EN 14527 e ottenendo così il marchio CE per i nostri piatti doccia.

ANTIBACTERIANO | ANTIBACTERIAL | ANTIBACTÉRIEN | ANTIBATTERICO

Es un aditivo antimicrobiano idóneo para una amplia variedad de materiales poliméricos. La tecnología patentada por NBM está basada en arcilla funcionalizada con plata, comportándose como una fuente natural altamente eficaz de agente antimicrobiano. Este aditivo inhibe el crecimiento de bacterias, hongos y levaduras, siendo por tanto, una herramienta muy eficaz frente a olores y manchas.

It is a suitable antimicrobial additive for a wide variety of polymeric materials. NBM's patented technology is based on silver-functionalized clay, behaving as a highly effective natural source of antimicrobial agent. This additive inhibits the growth of bacteria, fungi and yeasts, making it a highly effective tool against odors and stains.

Il s'agit d'un additif antimicrobien adapté à une grande variété de matériaux polymères. La technologie brevetée de NBM est basée sur de l'argile fonctionnalisée à l'argent, qui se comporte comme une source naturelle très efficace d'agent antimicrobien. Cet additif inhibe la croissance des bactéries, des champignons et des levures, ce qui en fait un outil très efficace contre les odeurs et les taches.

È un additivo antimicrobico adatto a un'ampia varietà di materiali polimerici. La tecnologia brevettata da NBM si basa sull'argilla funzionalizzata con argento, che si comporta come una fonte naturale di agente antimicrobico altamente efficace. Questo additivo inibisce la crescita di batteri, funghi e lieviti, rendendolo uno strumento altamente efficace contro odori e macchie.

ANTIDESLIZANTE C3 | ANTISLIP C3 | ANTIDÉRAPANT C3 | ANTISCIVOLO C3

Antideslizante C3 seguro, cálido y agradable al contacto de la piel.

Los platos de ducha a medida pueden tener de +/- 1% con respecto a las medidas solicitadas.

Anti-slip C3 safe, warm and pleasant to the skin contact.

Custom shower trays can have +/- 1% with respect to the requested measurements.

Antidérapant C3, sûr, chaud et agréable pour la peau.

Les receveurs de douche sur mesure peuvent avoir une différence de +/- 1% par rapport aux mesures demandées.

Antiscivolo C3, sicuro, caldo e piacevole per la pelle.

I piatti doccia su misura possono avere una differenza del +/- 1% rispetto alle misure richieste.



Antibacteriano

Antibacterial
Antibactérien
Antibatterico



Resistente a altas temperaturas

High temperature resistant
Résistant aux fortes températures
Resistente alle alte temperature



Resistente a agentes químicos

Chemical agents resistant
Résistant aux agents chimiques
Resistente ai prodotti chimici



Antideslizante C3-R11

Antislip C3-R11
Antidérapant C3-R11
Antiscivolo C3-R11

EMBALAJE PLATOS DE DUCHA



Palet tratado térmicamente según normativa.
Pallet treated pallet according to regulations
Palette traitée thermiquement conformément à la réglementation
Palet trattato termicamente secondo gli standard

PACKING SHOWER TRAYS | EMBALLAGE DES RECEVEUR DE DOUCHE | IMBALLAGGIO PIATTI DOCCIA

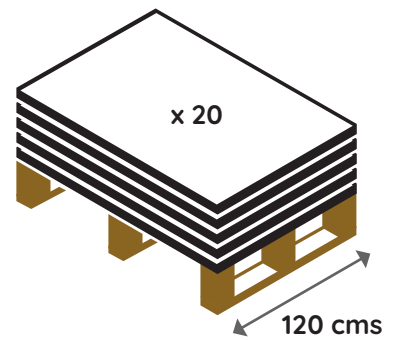
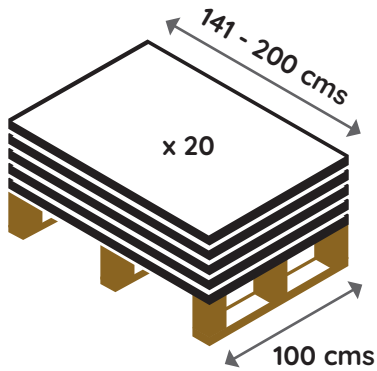
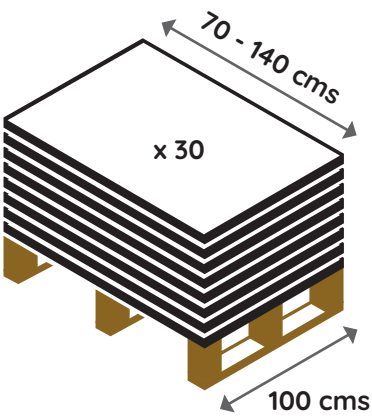
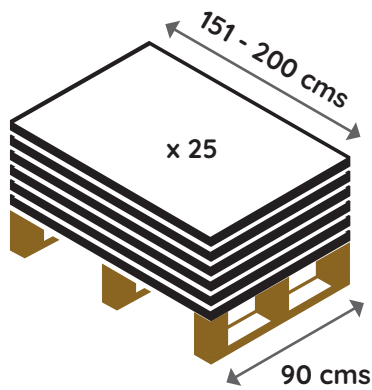
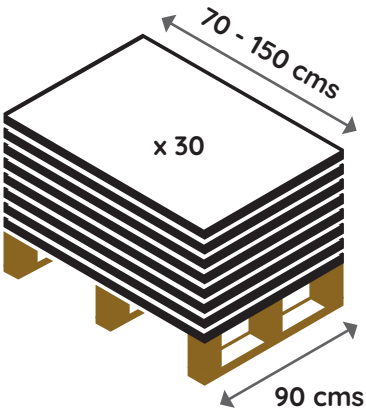
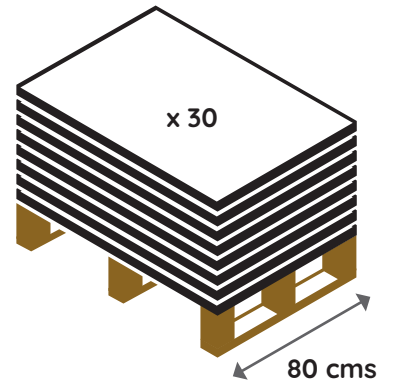
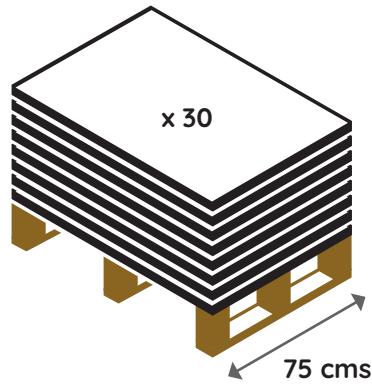
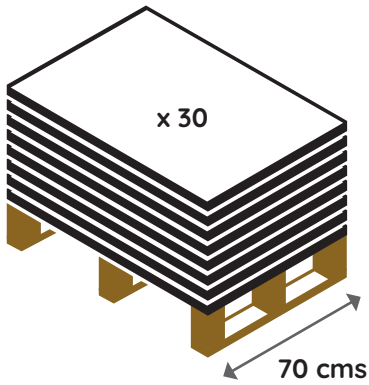

INSTRUCCIONES DE CORTES DE PLATOS DE DUCHA

CUTTING INSTRUCTIONS | INSTRUCTIONS DE COUPE | ISTRUZIONI DI TAGLIO

IMPORTANTE - INSTRUCCIONES CORTES DE PLATOS DUCHA

- Nuestros platos están fabricados en gel coat sobre molde.
- Los cuatro cantos de los platos tienen la misma terminación que la superficie.

BASES PARA EL CORTE

- Los cortes sobre el lado largo se realizaran en la parte de la válvula y se vera reducida la distancia al alojamiento de la pared en los centímetros que se tengan que cortar.
- En los cortes laterales inferiores a 5 centímetros se indicara lado de la pared.
- Los cortes que no se tengan que repintar serán sin cargo.
- Los cortes que se indiquen que tiene que ir terminados con pintura sufrirán un incremento indicado en tarifa apartado complementos.

IMPORTANT - CUTTING INSTRUCTIONS

- Our plates are made of gel coat on a mould.
- The four edges of the plates have the same finish as the surface.

BASES FOR CUTTING

- Cuts on the long side shall be made on the valve side and the distance to the wall housing shall be reduced by the centimetres to be cut.
- For side cuts shorter than 5 centimetres, the side of the wall shall be indicated.
- Cuts that do not have to be repainted will be free of charge.
- The cuts that are indicated as having to be finished with paint will be subject to an increase indicated in the price list in the complements section.

IMPORTANT - INSTRUCTIONS DE COUPE

- Nos plaques sont fabriquées en gelcoat sur un moule.
- Les quatre bords des plaques ont la même finition que la surface.

BASE DE DÉCOUPAGE

- Les coupes sur le grand côté doivent être effectuées du côté de la vanne et la distance par rapport au boîtier de la paroi doit être réduite du nombre de centimètres à couper.
- Pour les coupes latérales inférieures à 5 centimètres, le côté du mur doit être indiqué.
- Les coupes qui ne doivent pas être repeintes sont gratuites.
- Les coupes pour lesquelles il est indiqué qu'elles doivent être peintes feront l'objet d'une majoration indiquée dans la liste de prix, dans la section des compléments.

IMPORTANTE - ISTRUZIONI DI TAGLIO

- Le nostre piastre sono realizzate in gel coat su stampo.
- I quattro bordi delle piastre hanno la stessa finitura della superficie.

BASE PER IL TAGLIO

- I tagli sul lato lungo devono essere eseguiti sul lato della valvola e la distanza dall'alloggiamento della parete deve essere ridotta dei centimetri da tagliare.
- Per i tagli laterali inferiori a 5 centimetri, dovrà essere indicato il lato della parete.
- I tagli che non devono essere riverniciati sono gratuiti.
- I tagli per i quali è indicata la necessità di riverniciatura saranno soggetti a una maggiorazione indicata nel listino prezzi nella sezione complementi.

CORTES DE PLATOS DE DUCHA

CUTTING SHOWER TRAYS | DÉCOUPE DE RECEVEURS DE DOUCHE |
TAGLIO DEI PIATTI DOCCIA

ANGULAR IZQUIERDA

ANGOLARE SINISTRO / ANGULAIRE GAUCHE
ANGULAR LEFT

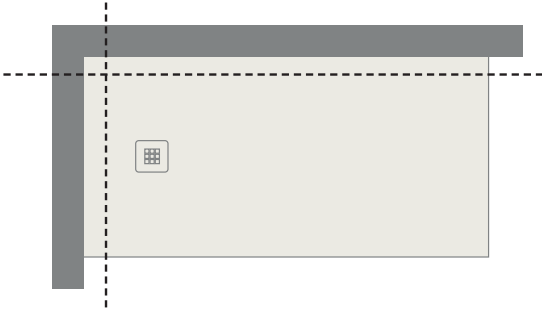

ANGULAR DERECHA

ANGOLARE DESTRO / ANGULAIRE DROITE
ANGULAR RIGHT



3 PAREDES LADO LARGO IZQUIERDA

3 PARETI LATO LUNGO SINISTRO / 3 MURS LONG
CÔTÉ GAUCHE / 3 WALLS LONG SIDE LEFT

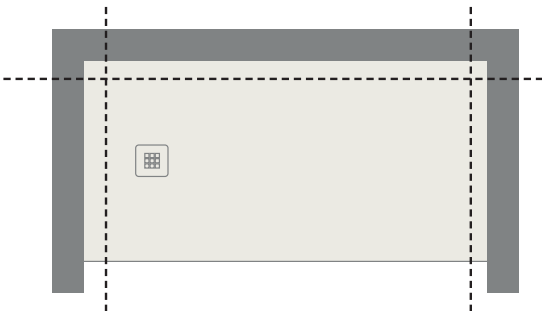

3 PAREDES LADO LARGO DERECHA

3 PARETI LATO LUNGO DESTRO / 3 MURS LONG
CÔTÉ DROITE / 3 WALLS LONG SIDE RIGHT

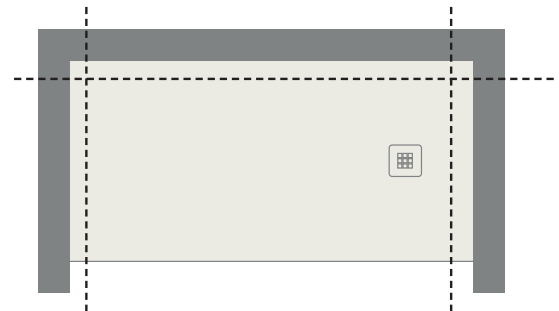

3 PAREDES LADO ANCHO IZQUIERDA

3 PARETI LARGHE LATO SINISTRO / 3 MURS LARGES
CÔTÉ GAUCHE / 3 WALLS WIDE SIDE LEFT

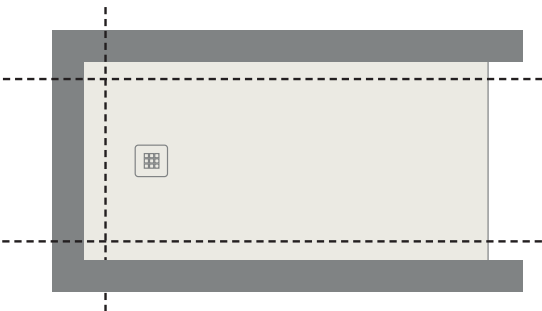

3 PAREDES LADO ANCHO DERECHA

3 PARETI LARGHE LATO DESTRO / 3 MURS LARGES
CÔTÉ DROITE / 3 WALLS WIDE SIDE RIGHT

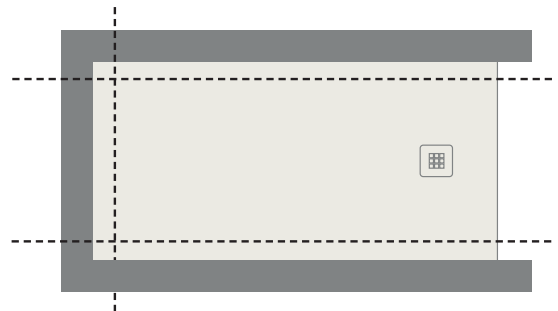

CONTRA PARED IZQUIERDA

CONTRO LA PARETE SINISTRA / CONTRE
LE MUR GAUCHE / AGAINST LEFT WALL



CONTRA PARED DERECHA

CONTRO LA PARETE DESTRA / CONTRE
LE MUR DROIT / AGAINST RIGHT WALL



MANTENIMIENTO PLATOS DE DUCHA

CLEANING | NETTOYAGE | PULIZIA

MANTENIMIENTO:

La limpieza y el mantenimiento de los platos de ducha Valbath no requieren ningún mantenimiento específico. Por lo general, es suficiente con enjuagarlos correctamente y procurar que no queden restos de productos de limpieza después de limpiar con un paño suave.

En la limpieza de nuestros platos de ducha debemos evitar el uso de ácidos, alcoholes o productos abrasivos.

A continuación se presentan los resultados de durabilidad del plato frente a la exposición de diferentes agentes químicos utilizados habitualmente en los ambientes de baño.

UNE - EN 14527 - APTITUD PARA LA LIMPIEZA

PRODUCTO	EFEECTO	PRODUCTO	EFEECTO
Lejía	24 h (5)	Acetona	1 min (1)
"Salfuman"	4 h (1)	Isopranol	5 min (5)
"Don Limpio"	24 h (3)	Tinte de pelo oscuro	5 min (2)
"Viakal"	24 h (4)	Tinte de pelo medio	5 min (2)
Vinagre	24 h (2)	Laca de uñas oscura	5 min (3)
Amoniaco	24 h (4)	Laca de uñas clara	1 h (5)
"KH-7"	24 h (5)	Agua oxigenada	24 h (3)
"Cilit Bang"	24 h (5)	"Betadine"	1 min (3)

VALORES | 0 - Película atacada. | 1 - Degradación superficial y/o formación de ampollas. | 2 - Cambio importante de brillo y/o color. | 3 - Cambio moderado de brillo y/o color. | 4 - Cambio ligero de brillo o color sólo visible desde ciertos ángulos de inspección. | 5 - Sin cambios visibles."

ENTRETIEN:

Le nettoyage et l'entretien des receveurs de douche Valbath n'exigent aucune opération spécifique. En règle générale, il suffit de les rincer correctement et d'éliminer les restes de produits de nettoyage à l'aide d'un chiffon doux. Pour le nettoyage de nos receveurs de douche, il faut éviter d'utiliser des produits acides, abrasifs ou à base d'alcool. Voici les résultats de durabilité du receveur de douche lorsque celui-ci est exposé aux différents agents chimiques utilisés habituellement dans les espaces de salles de bains.

UNE - EN 14527 - APTITUDE AU NETTOYAGE

PRODUIT	EFFET	PRODUIT	EFFET
Eau de Javel	24 h (5)	Acétone	1 min (1)
Acide chlorhydrique	4 h (1)	Isopropanol	5 min (5)
"Monsieur Propre"	24 h (3)	Teinture de cheveux, couleur foncée	5 min (2)
"Viakal"	24 h (4)	Teinture de cheveux, couleur moyenne	5 min (2)
Vinaigre	24 h (2)	Vernis à ongles foncé	5 min (3)
Ammoniaque	24 h (4)	Vernis à ongles clair	1 h (5)
"KH-7"	24 h (5)	Eau oxygénée	24 h (3)
"Cilit Bang"	24 h (5)	"Bétadine"	1 min (3)

VALEURS | 0 - Pellicule attaquée. | 1 - Dégradation superficielle et/ou cloquage. | 2 - Changement important d'éclat et/ou couleur. | 3 - Changement modéré d'éclat et/ou couleur. | 4 - Changement léger d'éclat ou couleur visible uniquement sous certains angles d'inspection. | 5 - Sans changements visibles.

MAINTENANCE:

Cleaning and maintenance of Valbath shower trays do not require any specific maintenance. Usually, rinsing them properly and ensuring that there is no cleaning product residue after cleaning with a cloth soft is sufficient.

In the cleaning of our shower trays, we shall avoid the use of acids, alcohol, or abrasive products.

Below, we can see the tray durability results to exposure to the various chemicals commonly used in bathroom settings.

UNE - EN 14527 - SUITABILITY FOR CLEANING

PRODUCT	EFFECT	PRODUCT	EFFECT
Bleach	24 h (5)	Acetone	1 min (1)
Hydrochloric acid	4 h (1)	Isopranol	5 min (5)
"Mr. Clean"	24 h (3)	Dark hair dye	5 min (2)
"Viakal"	24 h (4)	Medium hair dye	5 min (2)
Vinegar	24 h (2)	Dark nail lacquer	5 min (3)
Ammonia	24 h (4)	Light nail lacquer	1 h (5)
"KH-7"	24 h (5)	Hydrogen peroxide	24 h (3)
"Cilit Bang"	24 h (5)	"Betadine"	1 min (3)

VALUES | 0 - Damaged film. | 1 - Surface degradation and/or blistering. | 2 - Significant change of gloss and/or color. | 3 - Moderate change of gloss and/or color. | 4 - Slight change in gloss or color only visible from certain inspection angles. | 5 - No visible changes.

MANUTENZIONE:

"La pulizia e la manutenzione dei piatti doccia Valbath non richiedono alcuna manutenzione specifica. In generale, è sufficiente sciacquarli correttamente e cercare di non lasciare resti di prodotti per la pulizia passando un panno morbido. Per la pulizia dei nostri piatti doccia si deve evitare l'uso di acidi, alcol o prodotti abrasivi. Di seguito, vengono elencati i risultati di durezza del piatto doccia soggetto all'esposizione a diversi agenti chimici impiegati abitualmente nei bagni."

UNE - EN 14527 - IDONEITÀ ALLA PULIZIA

PRODOTTO	EFFETTO	PRODOTTO	EFFETTO
Varechina	24 h (5)	Acetone	1 min (1)
Acido cloridrico	4 h (1)	Isopropanol	5 min (5)
"Mastro Lindo"	24 h (3)	Tinta per capelli scura	5 min (2)
"Viakal"	24 h (4)	Tinta per capelli media	5 min (2)
Aceto	24 h (2)	Smalto per unghie scuro	5 min (3)
Ammoniacca	24 h (4)	Smalto per unghie chiaro	1 h (5)
"KH-7"	24 h (5)	Acqua ossigenata	24 h (3)
"Cilit Bang"	24 h (5)	"Betadine"	1 min (3)

VALORI | 0 - Pellicola intaccata. | 1 - Degradazione superficiale e/o formazione di bolle. | 2 - Variazione notevole di lucentezza e/o colore. | 3 - Variazione moderata di lucentezza e/o colore. | 4 - Variazione lieve di lucentezza o colore visibile solo da determinati angoli di controllo. | 5 - Senza modifiche visibili.

CERTIFICADOS Y GARANTÍA

CERTIFICATES AND WARRANTY | CERTIFICATS ET GARANTIE | CERTIFICATI E GARANZIA

Se garantizan los productos expuestos en este catálogo frente a cualquier defecto de fabricación durante 5 años desde la fecha de compra. La empresa no se hará cargo de los gastos que se originen de la sustitución de mamparas y/o cerámica colocados sobre el plato, en el caso de que el instalador no haya verificado la correcta instalación del plato y comprobado que desagua perfectamente, antes de terminar su correcta instalación.

Para una correcta limpieza de baños, abstenerse de utilizar productos que contengan disolventes o ácidos, así como estropajos o abrasivos.

Debido a los procesos de impresión, los colores que aparecen en este catálogo deben considerarse aproximados, no exactos. Queda prohibido cualquier tipo de reproducción total o parcial de las imágenes, textos, ilustraciones y grafismos del catálogo.

**CERTIFICADO DE GARANTÍA INCLUIDO EN EL EMBALAJE.
ESTE CATÁLOGO ANULA TODOS LOS ANTERIORES.**

The products shown in this catalog are guaranteed against any manufacturing defect for 5 years from the date of purchase. The company will not be responsible for the expenses arising from the replacement of screens and/or ceramics placed on the tray, in the event that the installer has not verified the correct installation of the tray and checked that it drains perfectly, before completing its correct installation. For a correct cleaning of bathrooms, refrain from using products containing solvents or acids, as well as scouring pads or abrasives.

Due to the printing process, the colors that appear in this catalog should be considered approximate, not exact. Any total or partial reproduction of the images, texts, illustrations and graphics in the catalog is prohibited.

**WARRANTY CERTIFICATE INCLUDED IN THE PACKAGING.
THIS CATALOG CANCELS ALL PREVIOUS CATALOGS.**

Les produits présentés dans ce catalogue sont garantis contre tout défaut de fabrication pendant 5 ans à compter de la date d'achat. L'entreprise ne sera pas responsable des frais liés au remplacement des grilles et/ou des céramiques placées sur le bac, au cas où l'installateur n'aurait pas vérifié l'installation correcte du bac et contrôlé qu'il s'écoule parfaitement, avant d'en réaliser l'installation correcte. Pour un nettoyage correct des salles de bains, il faut éviter d'utiliser des produits contenant des solvants ou des acides, ainsi que des tampons à récurer ou des abrasifs.

En raison du processus d'impression, les couleurs qui apparaissent dans ce catalogue doivent être considérées comme approximatives et non exactes. Toute reproduction totale ou partielle des images, textes, illustrations et graphiques du catalogue est interdite.

**CERTIFICAT DE GARANTIE INCLUS DANS L'EMBALLAGE.
CE CATALOGUE ANNULE TOUS LES CATALOGUES PRÉCÉDENTS.**

I prodotti illustrati in questo catalogo sono garantiti da qualsiasi difetto di fabbricazione per 5 anni dalla data di acquisto. L'azienda non sarà responsabile di eventuali spese derivanti dalla sostituzione di griglie e/o ceramiche poste sulla vaschetta, nel caso in cui l'installatore non abbia verificato la corretta installazione della vaschetta e controllato che questa scarichi perfettamente, prima di completare la sua corretta installazione.

Per una corretta pulizia dei bagni, astenersi dall'utilizzare prodotti contenenti solventi o acidi, nonché spugne o abrasivi.

A causa del processo di stampa, i colori che appaiono in questo catalogo devono essere considerati approssimativi, non esatti. È vietata la riproduzione totale o parziale delle immagini, dei testi, delle illustrazioni e della grafica del catalogo.

**CERTIFICATO DI GARANZIA INCLUSO NELLA CONFEZIONE.
QUESTO CATALOGO ANNULLA TUTTI I CATALOGHI PRECEDENTI.**

