



**valbath**  
Innovación para el baño



**BAÑERAS**  
BATHTUBS | BAINOIRES | VASCAS

**CÓRDOBA**

**SOLID SURFACE**



**Colores disponibles** | Available colors | Couleurs disponibles | Colori disponibili



**BLANCO**    **ALBERO**    **HUMO**    **TUNDRA**    **NEGRO**

**Lacado exterior**  
Exterior lacquered | Laquage extérieur | Laccatura esterna

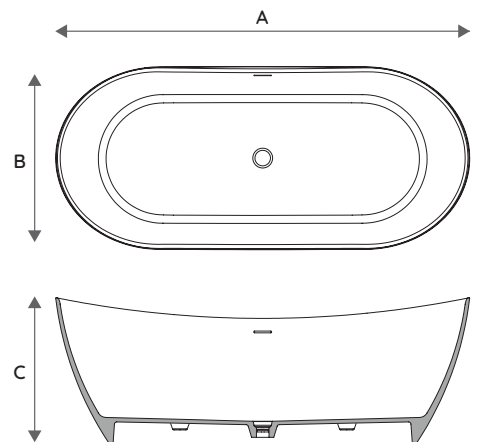

**Rebosadero** | Overflow  
Déborder | Traboccare



**Canto fino** | Fine edge  
Beaux chants | Canto fine



REF	A	B	C
C180	180	80	63



**valbath**  
Innovación para el baño



**BAÑERAS**  
BATHTUBS | BAINOIRES | VASCAS

**CÓRDOBA**

**SOLID SURFACE**

## TECHNICAL CHARACTERISTICS

### PERFORMANCE PROPERTIES

PROPIEDAD	TEST METHOD	VALOR
Appearance and cleanability (evaluation)	UNE -EN 14516+A1	Correct
Water evacuation (evaluation)	UNE -EN 14516+A1	Correct*
Stability of the fund (evaluation)	UNE -EN 14516+A1	No stagnation Correct
Resistance to chemicals and dyes (evaluation)	UNE -EN 14516+A1	No deterioration Correct
Resistance to temperature variations (evaluation)	UNE -EN 14516+A1	No deterioration Correcto

TEST CONDUCTED	TEST METHOD	RESULT
Resistance to dry heat at 180°. Appearance (evaluation)	UNE-EN 14688 Apartado 54	Correcto
Resistance to dry heat at 180°. Defects (evaluation)	UNE-EN 14688 Apartado 54	Sin defectos Correcto

TEST REPORT nº 221.I.2007751ES.01 FOR WASHBASINS DONE FOR AIDIMME.

TEST CONDUCTED	TEST METHOD	RESULT
Protección contra el desbordamiento Caudal del rebosadero(l/s)	EN 14688 Apartado 59	0,25 (0,01)